

2010-2011

Illinois TSA

**Competitive Events
Guide**

CONTENTS

EVENT	PAGE
GENERAL RULES	3 -5
Architectural Model	6-8
Chapter Team - Written	9
Creed	10-11
Computer-Aided Design Engineering	12-13
Dragster Design	14-18
Extemporaneous Presentation	19-21
Imaging Technology	22-23
Marine Challenge	24-25
Prepared Presentation	26-28
Promotional Graphics	29-30
Safety in Technology	31-32
Structural Engineering - Truss	33-35
Structural Engineering – Bridge	36-39
Sweepstakes Award	40
Technical Design	41-43
Technology Bowl - Oral	44-46
Technology Bowl - Written	47-48
Technology Problem Solving	49-51
TSA Student of the Year	52-56

GENERAL RULES

I. COMPETITIVE EVENTS

The 2010-11 officially approved Level 1 competitive events for IL-TSA are:	The 2010-11 officially approve Level 2 competitive events for IL-TSA are:
Architectural Model Chapter Team Written Creed Dragster Design Extemporaneous Presentation Imaging Technology Marine Challenge Prepared Presentation Promotional Graphics Safety in Technology Challenge Student of the Year Structural Engineering Sweepstakes (not an event, but an award) Technical Design Technology Bowl Oral Technology Bowl Written Technology Problem Solving Competitions	Architectural Model Chapter Team Written Creed Computer-Aided Design Engineering Dragster Design Extemporaneous Presentation Imaging Technology Marine Challenge Prepared Presentation Promotional Graphics Safety in Technology Challenge Student of the Year Structural Engineering Sweepstakes (not an event, but an award) Technical Design Technology Bowl Oral Technology Bowl Written Technology Problem Solving Competitions

II. LEVELS OF COMPETITION

The IL-TSA competitive events are divided into two (2) levels of competition, Level I for students in Middle Schools including grades 6-9, and Level II for students in grades 10-12. These levels allow for participation of members in competition with students more nearly their own age and skill level. In Senior High schools with members in grades 9-12, ninth graders will compete in Level I.

III. PARTICIPATION

- In chapter and team events, a TSA chapter must enter the event according to the level which corresponds to its official school classification.
- Students and advisors must be registered for the State Conference to compete in any of the competitive events, regardless of competitive events that are completed at the local school and brought to the State Conference.
- TSA members, advisors, and chapters, must be in good standing with TSA to enter any competitive event.
- TSA membership rights extend through the entire year of graduation. It is permissible for students who graduate at mid-term to compete at the State Conference which immediately follows their graduation.

IV. ENTRY RESTRICTIONS

See current year's State Events for specific participant rules.

(Note: Events for which no levels are listed have only one level of competition)

V. AWARDS

Awards will be presented to the winning entries in each competitive event at the Awards Presentation Ceremony. In most cases, first through third place awards will be presented.

VI. COMPETITIVE EVENTS ATTIRE

During most events, students must wear official or professional attire as described in the files found on the IL-TSA web site (<http://www.iltsa.org/files.html>). It is the responsibility of each advisor and contestant to be informed concerning acceptable dress for each event. Failure to dress appropriately may result in contestants not being allowed to compete.

VII. ADDITIONAL CONCERNS

- In the event a question or problem arises that has not been covered in the "General Rules" or the individual competitive event guidelines, the Competitive Events Committee will render a decision for the conference.
- Should a conflict develop which prevents a member from participating in all of his/her selected events, the contestant will decide which event will be eliminated.
- It is the individual responsibility of all contestants to obtain rules and guidelines for all events which they would like to enter. Lack of knowledge or understanding about a particular event will not be a reason or excuse for individual changes or adjustment considerations.
- Contest concerns during the State Conference, for any event, should be submitted in writing to the Competitive Events Coordinator to be considered by the Competitive Events Committee.

ARCHITECTURAL MODEL

OVERVIEW: TSA members entering the Architectural Model Event are required to submit a floor plan and a three-dimensional model of the specified structure according to the directions for that year.

I. CONTEST PURPOSE

The purpose of the Architectural Model Contest is to provide a means for TSA members to demonstrate their ability to design, draw, and construct an architectural model to scale.

II. ELIGIBILITY FOR ENTRY

- All IL-TSA members in good standing are eligible to enter the Architectural Model Contest.
- There is no limit to the number of entries that a chapter may enter.
- A member may enter only one model in the Architectural Model Competition.

III. LEVELS OF COMPETITION

There are two (2) levels of competition in the Architectural Model Contest, Level I (grades 6-9) and Level II (grades 10-12), as described in the General Rules.

IV. TIME LIMITATIONS

The Architectural Model Contest is not a "timed" event. The only time requirement is that the model must be constructed during the present school year.

V. SPECIFIC REGULATIONS

- The Architectural Model entry cannot be placed on a site board larger than 24" square.
- The roof of the model must be removable to allow inspection of the inside details.
- Materials that may be used in constructing the architectural model include, but are not restricted to the following:
 - Balsa wood
 - Plywood - not to exceed 1/4" in thickness
 - Hardboard or paneling - not to exceed 1/4" in thickness
 - Styrofoam/urethane (firm textured)
 - Dowels - not to exceed 1/4" diameter
 - Illustration board
- Glass or liquid may not be used.

- A complete list of materials shall accompany each entry.
- Floor and wall coverings such as rugs, linoleum, wallpaper, etc. may be used in construction.
- No furniture is to be included.
- Commercial kits are not permissible.
- A floor plan designed and drawn by the member submitting the entry must accompany each Architectural Model. Only the floor plan shall be submitted. Other drawings are not allowed. The maximum size for drawings shall be 11" X 17".
- Specific guidelines and model specifications shall be set by the IL-TSA Competitive Events Committee in consultation with the Board of Directors for each year or years as deemed necessary by the board. These specific guidelines shall be made available to each IL-TSA chapter annually. Specific guidelines shall be set for Level I and Level II entries.

VI. PROCEDURE

- Contest participants must register for the event in accordance with procedures established for each conference.
- Contestants must have the Architectural Model in the judging area before the time deadline specified in the conference program.
- Architectural Model entries may be picked up at the designated time.

VII. REQUIRED CONTEST PERSONNEL AND EQUIPMENT

- Contest coordinator
- A team of judges - ideally three but fewer are acceptable
- Display tables for Architectural Model entries
- Judge's rating sheets

VIII. CRITERIA FOR JUDGING

- Architectural Model entries shall be evaluated using the following criteria.

Quality of drawing	15 points
Overall Appearance	10 points
Quality of Construction	15 points
Creativity and Innovation	10 points
Meets Design Problem Criteria	15 points
Interior Planning	20 points
Interior planning includes traffic flow, placement of rooms, and planning within each room.	
Exterior Planning	10 points
Exterior planning includes landscaping (if applicable), how well the exterior compliments the environment, and how well the exterior compliments the structure.	
Materials List	5 points

TOTAL 100 points

- Awards first, second, and third place awards will be presented in each level of competition.

Architectural Model

Level I- "A-Frame House"

Minimum Requirements Include:

1250-2000 square feet	2 Bedrooms	2 Full Bathrooms
Kitchen	Dining Area	Living Area
Utility Room		

Level II- "Community Center"

Minimum Requirements Include:

4000-5000 square feet	Meeting Room(s)	Kitchen/Serving Area
Restrooms	Offices	Janitor/Maintenance Room
Gym/Recreation Area (not included in the square feet)		

CHAPTER TEAM - Written

OVERVIEW: Participants complete a written examination that includes parliamentary procedures and relative TSA meeting procedures.

I. CONTEST PURPOSE

The purpose of the Chapter Team Competition is to allow TSA members to demonstrate their ability to lead and follow accepted rules for conducting a business meeting.

II. ELIGIBILITY FOR ENTRY

- All IL-TSA chapters in good standing are eligible to enter the Chapter Team contest.
- Unlimited individual entries from each chapter are allowed for this competitive event.

III. LEVELS OF COMPETITION

There is one (1) level of competition in the Chapter Team Contest.

IV. TIME LIMITATIONS

Contest period.

V. SPECIFIC REGULATIONS

- Written materials such as the TSA handbook, minutes, etc., may not be taken into this contest by any member of the team.

VI. PROCEDURES

- Contest Participants must register and follow the guidelines for the event in accordance with the procedures established for each conference.

VII. REQUIRED CONTEST PERSONNEL AND EQUIPMENT

- Contest coordinator
- A copy of the contest guidelines
- Answer key to written examination

VIII. CRITERIA FOR JUDGING

Chapter Team contestants shall be rated using the following criteria:

Total number of questions answered correctly.

CREED

OVERVIEW: Contestants in the Creed Contest are required to recite the TSA Creed from Memory.

I. CONTEST PURPOSE

The purpose of the Creed Contest is to provide a means for TSA members to demonstrate their ability to memorize and recite the Creed.

II. ELIGIBILITY FOR ENTRY

- Entries are limited to two (2) per chapter.

III. LEVELS OF COMPETITION

There is one level of competition in the Creed Contest. Only members in Level I may compete.

IV. TIME LIMITATIONS

This is not a "timed" event. Each contestant will be given ample time for his/her presentation.

V. SPECIFIC REGULATIONS

- All contestants should report to the designated area on time. Contestants who fail to report on time will be disqualified.
- The Contest Coordinator will introduce each contestant by registration number.
- No written material or notes may be used.

VI. PROCEDURES

- Contest participants must register for this event in accordance with procedures established for each conference.
- Contest participants should assemble in the general area of the contest prior to the time designated for the contest.
- The contestant should begin by saying, "The Technology Student Association Creed..."
- An audience is permitted for this contest.

VII. REQUIRED CONTEST PERSONNEL AND EQUIPMENT

- Contest coordinator
- A team of judges - ideally three but fewer are acceptable - one of the judges should act as monitor to check the text for accuracy.
- A copy of the contest guidelines
- Judge's rating sheets
- Pens and pencils
- A copy of the TSA Creed for each judge
- A list of contestants in order of appearance
- A contest room with:
 - A podium
 - One table and three chairs for judges
 - Fifteen to twenty chairs for the audience
- A waiting area close to the contest room with:
 - A host to watch the door and regulate entrance into the contest room.
 - Chairs for contestants waiting for their turn to compete

VIII. CRITERIA FOR JUDGING

- The six paragraphs of the Creed shall count for a maximum of 168 points, one (1) point per word.
- Failure to say a word, saying a word incorrectly, or substituting words will result in penalties of one (1) point per word missed.
- Contestants saying a paragraph out of order will be notified at the end of the paragraph so that if they realize the mistake, they can go back and correct it with the loss of only ten (10) points.
- Each judge will complete, without consultation, a rating sheet for each entry. Points will be assigned according to the following:

Words of the Creed text	168 points
Clarity and Enunciation	7 points
Projection and Force	10 points
Poise (confidence, body control, and posture)	5 points
Personal appearance, grooming, and appropriate attire	10 points

COMPUTER-AIDED DESIGN ENGINEERING

OVERVIEW: TSA contestants demonstrate their technical knowledge of drafting by completing a written test and solving an engineering graphics problem using standard drafting techniques.

I. CONTEST PURPOSE

Use complex computer graphics skills, tools, and processes to develop two and/or three dimensional representations.

II. ELIGIBILITY FOR ENTRY

All IL-TSA chapters in good standing are eligible to enter the Computer-Aided Design Engineering contest.

Entries are limited to two individuals per chapter. This is a Level 2 competition only.

III. TIME LIMITS

Two hours to complete the written and performance part of the contest.

IV. REGULATIONS

- **Each contestant entering this competition is required to bring their own computer, monitor, etc., as well as software. No equipment will be available at the TSA competition site.**
- Participants must work independently.
- Each participant will print their solution within five minutes of the conclusion of the contest.
- Participants are not allowed to leave the contest area once the contest has started.
- Participants identify their work using only their conference identification number.

V. REQUIRED CONTEST PERSONNEL AND EQUIPMENT

- Contest coordinator
- A team of judges - ideally three, but fewer are acceptable
- A copy of the contest guidelines
- Written tests, pencils, and answer sheets
- Drawing paper, copies of problems, and correct solutions
- Judge's rating sheets
- Pens for judges
- Tables, chairs, and computers for contestants

VI. EVALUATION

Accuracy of solution	35 points
Placement of views	10 points
Accuracy of Drawing	20 points
Dimensioning	10 points
Correct Lettering	10 points
Correct Line quality	15 points
Written test score	100 points
TOTAL	200 points

Awards

First, Second, and Third place awards will be presented.

DRAGSTER DESIGN

OVERVIEW: TSA members entering the Dragster Design Contest are required to design, draw, and build a CO₂-powered model dragster. Design, speed, craftsmanship, and drafting skills are primary considerations in evaluation.

I. CONTEST PURPOSE

The purpose of the Dragster Design contest is to provide a means for TSA members to demonstrate and develop their ability to design, draw, and construct a product within a rigid set of specifications.

II. ELIGIBILITY FOR ENTRY

- All IL-TSA members in good standing are eligible to enter the Dragster Design Contest.
- There is no limit to the number of entries that a chapter may enter.
- A member may enter only one model in the Dragster Design Competition.
- A member entering the Dragster Design competition does not need to be in attendance at the State Conference.

III. LEVELS OF COMPETITION

There are two (2) levels of competition in the Dragster Design Contest, Level I (grades 6-9) and Level II (grades 10-12), as described in the General Rules.

IV. TIME LIMITATIONS

The dragsters entered in the Dragster Design contest at the state conference must have been constructed during the current school year. Dragsters which were constructed during a previous year are not eligible for entry even if they had not been entered in competition the previous year.

V. SPECIFIC REGULATIONS

- All entries must be submitted at the assigned time and place designated for each conference. Contestants are responsible for obtaining information on registration times.
- All entries must be delivered free of needed repair and/or maintenance at the time of check-in.
- CO₂ cartridges will be provided by IL-TSA.
- Each entry must be submitted with a full size metric drawing of the completed dragster. A two-view (top and side) drawing with metric dimensions shall be made on 11 x 17 drawing paper. A three-view (top, side, and end) drawing is acceptable but will not change the point allocations. Drawings should be developed using standard engineering procedures and practices. Drawings may be made using ink or pencil with traditional drafting methods or

CAD. Originals, blueprints, or copies will be accepted. The title block will only include "Entry Number _____," which will be assigned at registration time and placed on the entry prior to being turned in.

- The official distance between the start line and the finish line on the race track is twenty (20) meters (65'-7½"). If for any reason a distance other than twenty meters is used, that distance will remain constant for all entries in the event.
- Following a strict set of specifications is an integral part of this event. Dragsters that do not meet the following specifications and tolerances are disqualified from competition.

DRAGSTER SPECIFICATIONS AND TOLERANCES

DRAGSTER BODY

Body Blank - The body of the dragster shall be one-piece, all wood construction. No parts such as body strengtheners, fenders, plastic canopy, exhausts, or air foils may be attached to or enclosed within the dragster. Fiberglass or shrink wrap are considered body strengtheners and cannot be used on car body or wheels for any reason. Bearings and lubricants may be used in construction. Two or more like or unlike pieces of wood glued together will not be considered one-piece, all wood construction.

MINIMUM MAXIMUM

Body length	200mm	305mm
Body height at rear with wheels	56mm	75mm
Body mass with wheels	45g	170g without CO2 cartridge
Body width at axles, front & rear	35mm	42mm
Body total width including wheels	72mm	

AXLES, AXLE HOLES, WHEELBASE

Dragsters must have two (2) axles per car, no more. Plastic axles may be used in competition. However, design elements regarding impact should be considered when engineering the dragster.

Bottom of axle hole above bottom of car	5mm	10mm
Rear axle hole from rear of car	9mm	100mm
Wheelbase - distance between axle centers	105mm	270 mm

Bearings, bushings, and lubricants may be used.

POWER PLANT (CO2 cartridge) HOLE

The power plant hole is located at the farthest point at the rear of the car and must be drilled parallel to the bottom of the body blank to assure proper puncture of the CO2 cartridge. A minimum of 3 mm thickness around the entire power plant hole must be maintained on the dragster for safety.

Power plant hole depth	50mm52mm
Power plant safety zone thickness	3mm
Power plant chamber diameter	1 mm 20mm
Power plant hole location	31mm35mm

measure to center of hole from body bottom

EYE SCREWS

Dragsters must have two (2) eye screws per car that meet tolerances, no more. They must not make contact with the racing surface. The track string must pass through both screw both screw eyelets, which are located on the center line of the bottom of the car. Glue may be used to reinforce the eye screws in the body bottom. It is the responsibility of the car designer to see that the eye screw holes are tightly closed to prevent the track line from slipping out. As with all adjustments, this must be done prior to event check-in.

Eye screw inside diameter	3 mm 5mm
Eye screw spacing, distance apart	155mm 270mm

WHEELS

Dragsters must have four (4) wheels, no more. Front wheels must meet front wheel specifications and rear wheels must meet rear wheel specifications as listed below. All four wheels must touch the racing surface at the same time. All wheels must roll. The wheels must remain independent of each other. They may not be glued together. Wheels must be made entirely from plastic. Dimensions must be consistent for the full circumference of the wheel.

Front wheel diameter	32mm37mm
Front wheel width at surface contact point	2mm5mm
Rear wheel diameter	30mm 40mm
Rear wheel width at surface contact point	15 mm18 mm

SPACER WASHERS, CLIPS

Spacer washers	8
Axle clips	8

Silicone or any other type of glue or adhesive may not be used in place of wheel clips to hold wheels or axles in place.

- All contest entries will be judged according to the Dragster Design rating sheet, which includes criteria for drawing, design, race, speed, etc.
- No repair or maintenance on entries will be allowed after entries have been registered. Undamaged wheels which come off during the contest may be replaced as determined by the event coordinator. Damaged wheels may not be replaced.
- Any entry damaged during the race will be evaluated by the event coordinator to determine whether or not the vehicle is allowed to race again.
- In the event that the entry is damaged by conference personnel during evaluation or the race, the event coordinator will rule as to whether the vehicle may be repaired by the student entering the vehicle. This is the only reason a student is allowed to touch his/her vehicle after registration.

VI. PROCEDURE

- Contestants will register their dragsters with the Competitive Events Coordinator at the designated registration time.
- Instructions and contest time lines provided at registration will be followed. It will be the responsibility of each contestant to obtain these for each conference.
- At the time of registration, each dragster will be assigned an entry number. This number will be attached to the dragster by conference personnel who are working in the exhibit area.
- Races for each level of competition will be run separately. Each entry will race two (2) times. The better time for each entry will be counted for final evaluation of the dragster. All races for each level of competition will be run on the same side of the track.

VII. REQUIRED CONTEST PERSONNEL AND EQUIPMENT

- Contest coordinator
- A team of judges - ideally three but fewer are acceptable each entry will first be checked to be sure it meets the required specifications, qualifying entries will then be judged on design, drawing, and construction.
- Person assigned for security during registration
- Tables for entries
- Room or area to run the race
- Room or area to secure dragster entries
- 20 meter track with starting gate and timer
- CO2 cartridges - three (3) per entry plus spares

VIII. CRITERIA FOR JUDGING

- Entries shall be judged on design, drawing, and construction/craftsmanship. These three areas along with its race results will determine the final standing of each dragster. Judges will complete their evaluation of each entry without consultation with the other judges.
- Ratings shall be based upon the following:

Design 16 points

- a. Appearance - 8 pt.
- b. Finish - 8 pt.

Drawing 20 points

- a. Accuracy - 10 pt. (Dragster will be compared to the drawings and specifications)
- b. Neatness - 2 pt.
- c. Dimension accuracy - 2 pt.
- d. Point-to-point contact of arrow heads, extension lines, corner, etc. - 2 pt.
- e. Line quality - 2 pt.
- f. Irregular curves - 2 pt.

Construction/Craftsmanship 14 points

Race

1st Place	60 points
2nd Place	56 points
3rd Place	52 points
4th Place	48 points
5th & 6th Place	45 points
7th & 8th Place	40 points
9th - 12th Place	35 points
13th - 16th Place	30 points
17th - 24th Place	25 points
25th - 32nd Place	20 points

The Contest Coordinator will provide the Competitive Events Coordinator with a sealed packet containing the results.

All judge's ratings and results are to remain confidential.

EXTEMPORANEOUS PRESENTATION

OVERVIEW: TSA contestants in the Extemporaneous Presentation Contest are required to give a three (3) to five (5) minute speech, fifteen minutes after having drawn a card on which a topic for their speech is written.

I. CONTEST PURPOSE

The purpose of the Extemporaneous Presentation Contest is to provide a means for TSA members to demonstrate their knowledge of technological subjects and their ability to communicate that knowledge given a limited time to prepare a presentation.

II. ELIGIBILITY FOR ENTRY

- All IL-TSA members in good standing are eligible to enter the Extemporaneous Presentation contest.
- Entries are limited to two (2) per chapter.

III. LEVELS OF COMPETITION

There are two (2) levels of competition in the Extemporaneous Presentation Contest, Level I (grades 6-9) and Level II (grades 10-12), as described in the General Rules.

IV. TIME LIMITATIONS

Each speech shall be not less than three (3) minutes or more than five (5) minutes in length. A timekeeper shall notify the speaker of the time remaining for his/her speech. Time commences when the speaker begins talking.

V. SPECIFIC REGULATIONS

- Each speech shall be the result of the contestant's own effort, utilizing any reference materials which the contestant may bring to the preparation room.
- Note cards (3 X 5) and pencils will be provided by TSA for contestant's use in preparing their speeches.
- All notes for the presentation must be made during the fifteen (15) minute preparation period.
- Contestants may use their notes when speech. However, deductions in scoring may be made for this practice if it detracts from the effectiveness of the presentation.
- The timekeeper will record the time used by each contestant in delivering his/her speech. The timekeeper will note to the judges any under time or overtime for which deductions should be made, and inform the contestant of the amount of time remaining in minutes by using 5 x 7 cards with the numbers 4, 3, 2, 1, 1/2, and 0 placed on them and shown to the

contestant throughout the speech. Time shall be indicated to the contestant in descending order.

- Observers will not be allowed in the performance room during the Extemporaneous Presentation contest.
- Contestants will not be allowed to hear other contestant's presentations even though they have already given their own presentation.

VI. PROCEDURE

- Contestants must register for this event in accordance with procedures established for each conference.
- Students will sign up at the registration table for their time of presentation.
- Topic selection shall be held before each student enters the preparation room. Each student will draw three (3) cards, one topic per card, from a box, select one topic on which to speak, copy the topic on another card and return all cards to the box.
- After selection of a topic, the first student will enter the preparation room, separate from the speech delivery room, and will be given fifteen (15) minutes to prepare the speech.
- Seven (7) minutes after the first student enters the preparation room, the second student will enter the room, go to a different section, and begin his/her speech preparation, again given fifteen (15) minutes to prepare the speech.
- All remaining participants will be allowed to enter the preparation room in seven minute intervals, thus enabling a constant flow of students to speak before the judges in seven minute intervals. This time schedule allows for one minute to enter the room and announce the entry number, five minutes for the speech presentation, and one minute to exit the room.
- The Contest Coordinator shall introduce each contestant by the entry number in order of appearance.
- The contestant may introduce his/her speech by title only.
- After the speech, the student must leave his/her topic card with the judges.

VII. REQUIRED CONTEST PERSONNEL AND EQUIPMENT

- Contest coordinator
- A team of judges - ideally three but fewer are acceptable - one may act as the time keeper
- Speaker's stand
- Stopwatch
- Tables and chairs for three judges

- Judge's rating sheets
- One set of 5 x 7 cards with one of the following numbers on each card:
4, 3, 2, 1, 1/2, and 0
- 3 X 5 note cards for contestants speech preparation
- Pencils
- Results reporting form

VIII. CRITERIA FOR JUDGING

Each judge will complete a rating sheet for each contestant. The following criteria will be used.

Knowledge of Subject 20 points
Includes suitability of material used, accuracy of statements, and evidence of purpose

Organization of Material 20 points
Includes organization of content, unity of thought, logical development, language used, sentence structure, and accomplishment of purpose - conclusion

Power of Expression 20 points
Includes fluency, emphasis, directness, sincerity, communicative ability, and conveyance of thought and meaning

Voice 10 points
Includes quality, pitch, articulation, pronunciation, and force

Stage Presence 10 points
Includes personal appearance, poise and body posture, attitude, confidence, personality, and ease before an audience

General Effect 20 points
Based on the extent to which the speech was interesting, understandable, convincing, pleasing, and held the listener's attention

Time Deduction — _____
1 point per 10 second interval, or fraction thereof, under three (3) minutes or over five (5) minutes

IMAGING TECHNOLOGY

OVERVIEW: Participants capture images and process photographic and digital prints for display on a standard sized poster board (18" x 24" or 22" x 28") that depicts the current year's published theme. One entry per student (unlimited entries from chapter) is allowed for this competitive event. This event is completed at the home school and brought to the state conference for judging.

I. CONTEST PURPOSE

The purpose of the Imaging Technology contest is to provide a means for IL-TSA members to demonstrate their ability to communicate for a designated theme. **The 2011 Conference Theme is "Going Green".**

II. ELIGIBILITY FOR ENTRY

- All IL-TSA members in good standing are eligible to enter the Imaging Technology contest.
- One entry per student (unlimited entries from chapter) is allowed for this competitive event.

III. LEVELS OF COMPETITION

There are two levels of competition in the Imaging Technology contest

IV. TIME LIMITATIONS

This is not a "timed" event. The only restriction is that the entries must be submitted at the time specified for registration at each conference.

V. SPECIFIC REGULATIONS

- The Imaging Technology contest is an individual event. Entries should be the result of one member rather than a group.

VI. PROCEDURES

- Contest participants must register for this event in accordance with procedures established for each conference.
- At registration, each entry will be given an entry number by the contest coordinator. No other identifying marks will be allowed on the entry.
- No designs may be picked up before the designated time.
- All winning entries will become the property of IL-TSA and will be utilized as deemed appropriate by the Executive Committee and the Board of Directors in promoting the State Conference and IL-TSA.

VII. REQUIRED CONTEST PERSONNEL AND EQUIPMENT

- Contest coordinator

MARINE CHALLENGE

OVERVIEW: TSA teams entering the Marine Challenge event will design and construct a model marine vessel and/or vessel hull to be tested for payload strength and speed. This event is completed at the home school and brought to the state conference for judging/testing.

I. CONTEST PURPOSE

The purpose of the Marine Challenge Contest is to provide a means for TSA members to demonstrate their ability to design and fabricate a vessel after having been provided design guidelines.

II. ELIGIBILITY FOR ENTRY

- All IL-TSA members in good standing are eligible to enter the Marine Challenge Contest.

III. LEVELS OF COMPETITION

One entry per student (unlimited entries from chapter) is allowed for this competitive event. There are two (2) levels of competition in the Marine Challenge, Level I (grades 6-9) and Level II (grades 10-12), as described in the General Rules.

IV. TIME LIMITATIONS

None.

V. SPECIFIC REGULATIONS

- The vessel design must not be larger than 6" wide x 10" long x 2.5" deep
- The vessel must have a 1/4" diameter eye hook secured to the front, which is directly in the center – this eye hook is used to pull the vessel along a path
- The payload to be carried by the vessel will not weigh more than one pound and will be contained in an area not to exceed 3" x 3" x 3".

VI. PROCEDURE

- Teams must be registered in accordance with procedures established for each conference.
- All teams will construct their boat entries at the same time.
- Teams may test and redesign their boats until the two hour time limit has expired.
- No additional work may be done after the time limit has expired. All entries will be turned over to the judges for evaluation and testing.
- Boats shall be selected at random for testing.

VII. REQUIRED CONTEST PERSONNEL AND EQUIPMENT

- Contest Coordinator
- A team of judges - ideally three, but fewer are acceptable
- Stop watch to time event
- Reserved space for the testing equipment
- Testing equipment
 - Portable water tank
 - Water
 - All other necessary testing equipment will be provided
 - Calculator
- Evaluation forms

VIII. CRITERIA FOR JUDGING

The winner in this event is determined by the time required to travel a specified distance when a force is applied. The distance and force remain the same for all entrants. The variable is the design of the vessel hull.

PREPARED PRESENTATION

OVERVIEW: TSA members entering the Prepared Presentation Contest deliver an oral presentation not shorter than three minutes, but no longer than five minutes that includes audio and/or visual enhancement **based on the theme for the current year's conference: "Snapshot of Innovation"**.

I. CONTEST PURPOSE

The purpose of the Prepared Presentation Contest is to assist students in preparing for developing and delivering a prepared presentation in front of an audience/panel of judges.

II. ELIGIBILITY FOR ENTRY

Two individuals per chapter are allowed for this event.

III. LEVELS OF COMPETITION

There are two (2) levels of competition in the Prepared Presentation Contest, Level I (grades 7-9) and Level II (grades 10-12), as described in the General Rules.

IV. TIME LIMITATIONS

- Entries must be started and completed during the current school year.
- Each presentation must be no less than three (3) minutes and no more than five (5) minutes.
- A maximum of four (4) minutes is allowed for set-up.
- At the conclusion of the presentation, the participant must remove all materials within three (3) minutes.
- All students entered in the Prepared Presentation Contest will be assigned an appointment time and place for their interview. It is the responsibility of the student to be on time for his/her appointment.

V. SPECIFIC REGULATIONS

- Participants report to the event area at the time and place stated in the conference program to receive an assigned presentation time.
- Participants will report to the holding area, as stated in the conference program, fifteen (15) minutes prior to the assigned presentation time.
- The event coordinator introduces each participant by number and in order of scheduled times. The schedule allows time for set-up and removal of materials.

- No observers are allowed in the event or preparation rooms during heats, although they are allowed to sit in the audience of the performance during the finals. No talking or gesturing is permitted. Observers are NOT allowed to enter or leave during a presentation. THERE IS NO APPLAUSE UNTIL THE PRESENTATION HAS CONCLUDED. No form of visual recording (such as photographic or video) or audio recording by any observer (including family, friends, or advisors of the participants) is permitted.
- Each presentation must be the result of the participant's own efforts.
- The topic for the Prepared Presentation event is the published theme of the current year's conference. Information about technology and TSA is appropriate as long as it relates to the published theme.
- The presentation must include the use of audio and/or visual media materials.
- Examples of the audio/visual materials may include but are not limited to:
 - Charts and graphs
 - Posters
 - Displays
 - Flip charts
 - Transparencies
 - Models
- Participants are not allowed to hear other participants' presentations.
- A computer and projector will be available for use. Participants will need to have their presentations saved on a flash drive or CD to be placed on the TSA computer.
- An easel and a white background for a projection device are provided by TSA.
- Participant scores are penalized one (1) point per ten (10) second interval for speaking over or under the allotted time. The same penalty is used for set-up and takedown. Time commences when the presentation begins.

VI. EVALUATION

Evaluation is based upon the quality of the presentation and the appropriate use of audio/visual materials.

VII. REQUIRED CONTEST PERSONNEL AND EQUIPMENT

- Coordinator's notebook, containing:
 - Event guidelines, one (1) each for coordinator and evaluators
 - Official rating forms
 - List of entries with finalist report
 - List of evaluators/assistants
 - Marking pens or pencils for each evaluator
 - Semifinalist list for posting
 - One (1) stopwatch for each event room
 - Results envelope
- Podium, easel, and white background for projection
- Tables and chairs for three (3) evaluators
- Chairs for audience
- One (1) table, approximately 6' long, for participant's use
- Contest coordinator
- Two (2) judges
- Area or room that will house a computer and projector and/or poster board materials

VIII. CRITERIA FOR JUDGING

Presentation (70 pts.)

Introduction (interest and appeal) - 10 pts.

Knowledge of material (factual support) - 15 pts.

Organization (clarity and sequence) - 15 pts.

Stage presence (personal appearance, poise, posture, attitude, personality, and confidence) 10 pts.

Voice/language (grammar, pitch, pronunciation, articulation, and clarity) 10 pts.

Conclusion - 10 pts.

Use of audio/visual materials (30 pts.)

Creativity in use - 10 pts.

Quality of materials - 10 pts.

Transitions between media use - 10 pts.

Time deduction

One (1) point per ten (10)-second interval over or under the time allotted for the presentation, and the set-up and take-down.

Total 100 Points

PROMOTIONAL GRAPHICS

OVERVIEW: TSA contestants in the Promotional Graphics Contest develop computer-generated graphic design(s) that can be used as a TSA recruitment tool that **includes the theme for next year's conference "The Road to Success"**. Submissions should be on 8.5" x 11" paper. **This event is completed at the home school and brought to the state conference for judging.**

I. CONTEST PURPOSE

The purpose of the Promotional Graphics contest is to provide a means for TSA members to demonstrate their skills to show a specific process, tell a story, describe a place, or provide a solution to a problem.

II. ELIGIBILITY FOR ENTRY

- One entry per student (unlimited entries from chapter) is allowed for this competitive event.
- All IL-TSA members in good standing are eligible to enter the Photography contest.

III. LEVELS OF COMPETITION

There are two (2) levels of competition, Level I (grades 6-9) and Level II (grades 10-12) as described in the General Rules.

IV. TIME LIMITATIONS

This is not a "timed" event. The only restriction is that the entries must be submitted at the time specified for registration at each conference.

V. SPECIFIC REGULATIONS

- The Promotional Graphics contest is an individual event.
- Entries may be submitted on 8.5" x 11" paper.
- The title of the design be incorporated into the graphic.
- Captions under graphics may be used for identification purposes only. Captions should not be used to help tell the story as the graphics should be telling the story or describing the place.
- Specific requirements for each level of competition will be made available to members prior to each conference.

VI. PROCEDURES

- Contest participants must register for this event in accordance with procedures established for each conference.

- Entries must be entered during the designated contest registration time. Late entries will not be accepted.
- At registration, each entry will be given an entry number by the contest coordinator. No other identifying marks will be allowed on the entry.
- No entries may be picked up before the designated time.

VII. REQUIRED CONTEST PERSONNEL AND EQUIPMENT

- Contest coordinator
- A team of judges - ideally three but fewer are acceptable
- A copy of the contest guidelines
- Judge's rating sheets
- Pens and pencils
- Display area for entries, may be tables or may hang on wall
- Tape or push pins for displaying entries

VIII. CRITERIA FOR JUDGING

Entries shall be evaluated using the following criteria.

Impact (15 pts)

Effective communication of conference theme - 5 pts.

Appropriateness of design - 5 pts.

First impressions (sharp clean edges of graphics and fonts; entry is clear of smudges, smears, pencil or other extraneous marks) - 5 pts.

Graphic (15 pts)

Graphic is appropriate for stated theme - 10 pts.

Fonts are readable, have eye appeal, appropriate dimension and placement - 5 pts.

[Proof of permission to use copyrighted image(s) must be included. A release form must be present if photographs of individuals are used. Clipart must be documented.]

Design elements (40 pts)

Balance (visual weight of design elements) - 10 pts.

Dominance (eyes are drawn to main message) - 10 pts.

Proportion (size relationships within the design) - 10 pts.

Unity (design elements flow together) - 10 pts.

Rules violation (must be initialed by coordinator and manager)minus 20% of the total possible pts.

70 Points

Awards - First, Second, and Third place awards will be presented.

SAFETY IN TECHNOLOGY

OVERVIEW: The Safety in Technology contest is designed to direct attention to the area of technological safety. Contestants develop a graphic design(s) that communicates safety in a technological field. Submissions should be on 11" x 17" paper and/or poster board. **This event is completed at the home school and brought to the state conference for judging.**

The 2011 Safety in Technology Contest theme is "Electrical Safety in the Home"

I. CONTEST PURPOSE

The purpose of the Safety in Technology contest is to provide a means for TSA members to demonstrate their ability to recognize safety needs and to communicate safety messages in visual form.

II. ELIGIBILITY FOR ENTRY

- All IL-TSA members are eligible to enter the Safety in Technology Contest.
- There is no limit to the number of entries per chapter.

III. LEVELS OF COMPETITION

There are two (2) levels of competition, Level I (grades 6-9) and Level II (grades 10-12) as described in the General Rules.

IV. TIME LIMITATIONS

This is not a "timed" event. The only restrictions are that the posters must be completed prior to the state conference and that they must have been done during the present school year.

V. SPECIFIC REGULATIONS

- No member may enter more than one (1) poster.
- The Safety in Technology poster must be produced on 11 x 17 poster board, illustration board, or cardboard. Posters must be of a hanging type which can be mounted on a wall for exhibition.
- Contestants must not leave posters until entry numbers have been affixed to the back of the poster by an official. The entry number will be assigned during contest registration. The contestant's name, school, etc. must not appear anywhere on the poster.

STRUCTURAL ENGINEERING – Truss Design

OVERVIEW: Participants design and construct a model structure that is destructively tested to determine design efficiency. This event is completed at the home school and brought to the state conference for judging/testing.

I. CONTEST PURPOSE

The purpose of the Structural Engineering Contest is to provide a means for TSA members to demonstrate their ability to design and fabricate a structure after having been assigned span and width specifications.

II. ELIGIBILITY FOR ENTRY

- All IL-TSA members in good standing are eligible to enter the Structural Engineering Contest.
- One entry per student (unlimited entries from chapter) is allowed for this competitive event.

III. LEVELS OF COMPETITION

There are two (2) levels of competition in the Structural Engineering Contest, Level I (grades 6-9) and Level II (grades 10-12), as described in the General Rules.

IV. TIME LIMITATIONS

Since the structural artifacts are constructed prior to the state conference, there is no time limitation other than the artifacts must have been constructed during the current school year.

V. SPECIFIC REGULATIONS – 2011 (Structural Artifact: Roof Truss)

- Trusses must be constructed according to specifications.
- Trusses must be constructed according to the following definitions and graphic illustrations which are an integral part of the contest regulations.
- Span: The overall span of the truss must be between 10" and 16".
- Materials: No more than 20' of 3/32" x 3/32" basswood or balsawood and one 3" x 5" note card may be used to construct the truss. A maximum of 1 ounce of liquid adhesive may be used in the construction of the truss.
- Lamination: Two pieces of 3/32" x 3/32" beams glued together surface-to-surface with the wood grain running parallel. Lamination of more than two pieces is not permitted.

CORRECT LAMINATION



INCORRECT LAMINATION



Failure Weight: The greatest weight recorded during testing before failure of the structure. Failure to comply: If a structure fails to comply with any regulation, a penalty reduction of twenty percent (20%) of the greatest weight held in the contest is subtracted from the team's failure weight.

Gusset: A panel or bracket attached to corners or intersections of truss components to add strength or stiffness. Note cards may be cut and used as gussets to strengthen the joints of truss structures. Note card gussets on trusses are to be no larger than the diameter of a current issue American quarter dollar coin. The gussets may not touch another note card gusset or overlap other trusses. They may not be sandwiched between two (2) laminated members.

The structure must reach 1" beyond the abutments, plus or minus 1/8". The tester will be set at 8" for the 10" truss, 10" for the 12" truss, 12" 14" truss and 14" for the 16" truss.

The roof truss will need to be fabricated on a 5/12 slope. This simply means that the truss would rise vertically 5 units for every 12 units of horizontal run.

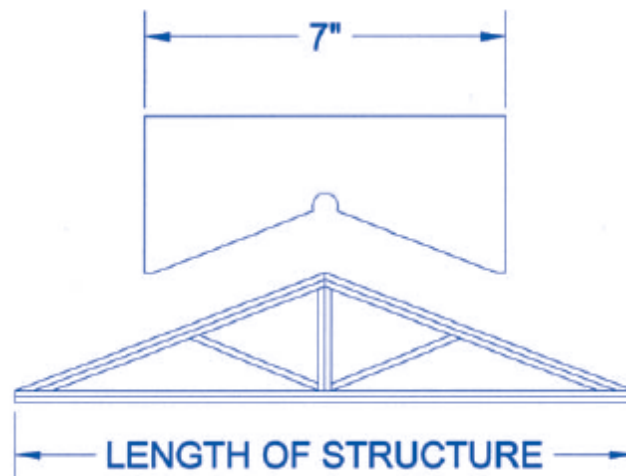

No part of the structure may extend below the plan of the abutments.

Truss members to simulate decking may be used above the truss to add stability. Internal members may be used to simulate cross bracing, but be certain to avoid blocking the center (the location of the testing rod).

The roof truss must be a triangle.

The peak of the truss is to be centered in the length of the truss.

VII. REQUIRED CONTEST PERSONNEL AND EQUIPMENT

- Contest Coordinator
- Assistant to help with testing

- Testing equipment
 - Appropriate testing equipment will be supplied
 - Scales
 - Calculator
- Evaluation forms

VIII. CRITERIA FOR JUDGING

- The structure is weighed before testing and the weight is recorded on the evaluation form.
- An increasing load is applied to the structure via the test block until the structure fails.
- The failure weight is recorded on the evaluation form.
- The efficiency is determined by the failure weight x 4.54 divided by the weight of the structure in grams.
- The efficiency is rounded off to three (3) decimal places and recorded on the evaluation form.
- The highest numeric efficiency is the winner. In case of an efficiency tie, the greatest weight held by the tied entries will be declared the winner.
- Structures that violate guidelines will receive a deduction of 20% of the greatest weight held for the first violation.
- Structures are not to be tested if
 - there are two (2) or more rule violations.
 - the structure cannot be placed on the tester.
 - the testing hook cannot be placed in the center of the structure.
 - straight pins are left in the structure.
 - there is a failure to wear safety eyewear.
 - there is evidence of conduct unbecoming a TSA conference participant during check-in, fabrication, or testing.

The structure is destructively tested using the breaker block shown below.

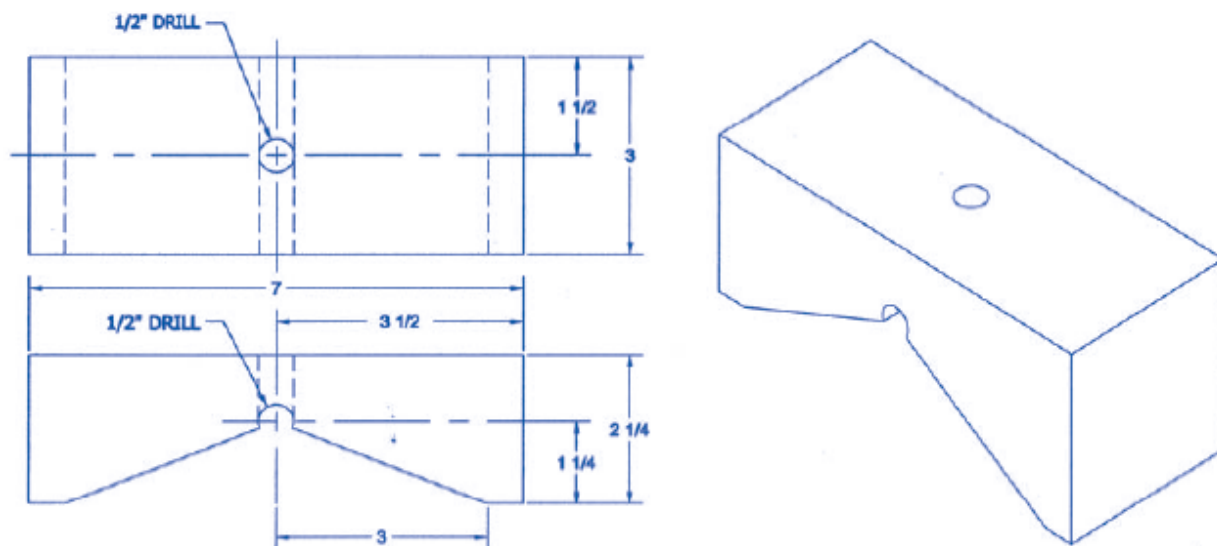

STRUCTURAL ENGINEERING – Bridge Design

OVERVIEW: Participants design and construct a model structure that is destructively tested to determine design efficiency. This event is completed at the home school and brought to the state conference for judging/testing.

I. CONTEST PURPOSE

The purpose of the Structural Engineering Contest is to provide a means for TSA members to demonstrate their ability to design and fabricate a structure after having been assigned span and width specifications.

II. ELIGIBILITY FOR ENTRY

- All IL-TSA members in good standing are eligible to enter the Structural Engineering Contest.
- One entry per student (unlimited entries from chapter) is allowed for this competitive event.

III. LEVELS OF COMPETITION

There are two (2) levels of competition in the Structural Engineering Contest, Level I (grades 6-9) and Level II (grades 10-12), as described in the General Rules.

IV. TIME LIMITATIONS

Since the structural artifacts are constructed prior to the state conference, there is no time limitation other than the artifacts must have been constructed during the current school year.

V. SPECIFIC REGULATIONS –

- Bridges must be constructed according to specifications.
- Bridges must be constructed according to the following definitions and graphic illustrations which are an integral part of the contest regulations.
- BRIDGE LENGTH: The overall length of the bridge, including the span and the required bearing surface area of the roadbed (1" minimum, 2" maximum) on the bridge supports.
- SUPER-STRUCTURE: The structure of the bridge which extends above the roadbed. The maximum width of the super-structure is 5 inches.
- SUB-STRUCTURE: The structure of the bridge which extends below the roadbed. The sub-structure may be no larger than 3 inches deep and 3 inches wide and must be centered crosswise under the roadbed.
- SPAN: The distance between bridge supports.
- TEST BLOCK: That piece of test apparatus to which the hook that holds the weight is attached. The length of which will be 2" less than the span. See Diagram C.

- **ROADBED:** The part of the bridge that is meant to be traveled upon. The roadbed must be maintained at a minimum width of 3" inside the supports. The bridge must be constructed to allow the test block (without the hook) to pass through the bridge opening on the roadbed from one end to the other. The roadbed must be flat and not greater than $1/4$ " thick.
- **FAILURE:** Once the test load is placed upon the bridge, failure is determined by one of the following:
 - the bridge collapses, or
 - any part of the sub-structure touches the bridge support systems.
- **LAMINATION:** Two pieces of $1/8$ " x $1/8$ " beams glued together surface-to-surface with the wood grain running parallel. Refer to Diagram B below for examples of correct and incorrect laminations.

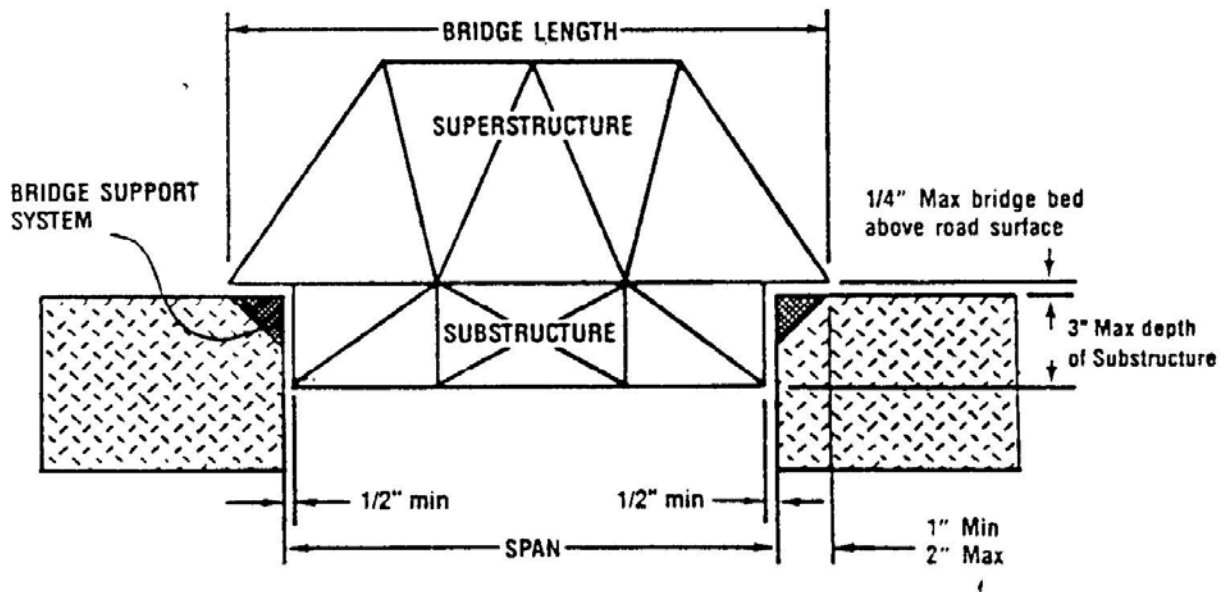
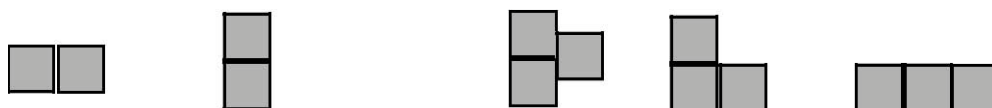

DIAGRAM A



CORRECT LAMINATIONS

INCORRECT LAMINATIONS

DIAGRAM B

- The exact span of the bridge to be built will be specified in the competitive events guidelines distributed at the beginning of the year with the affiliation materials. The specifications will be within the following limits:
- **Span - 8" minimum and 8.5" maximum; Width – 2.5" minimum and 3" maximum**
- **Bridges must be constructed in such a manner as to accommodate the test hook at the bridge's center.** The roadbed of the bridge must be free of obstructions.
- Coating of laminated beams with glue will not be permitted.

VI. PROCEDURE

- Bridge entries must be registered in accordance with procedures established for each conference.
- Bridge entries will be entered for competition along with all other exhibits during conference registration.
- All bridges will be evaluated by judges to determine their qualification for competition. Only qualified bridges will be tested in competition.
- Security shall be provided for all bridge entries as for all other exhibits.
- Bridges shall be selected at random for testing.

VII. REQUIRED CONTEST PERSONNEL AND EQUIPMENT

- Contest Coordinator
- Assistant to help with testing
- Testing equipment
 - Appropriate testing equipment will be supplied
 - Scales
 - Calculator
- Evaluation forms

VIII. CRITERIA FOR JUDGING

- Method to be used with a bridge testing machine.
 - Bridge efficiency shall be determined by the following formula:
 - Dividing the failure weight (Load) by the bridge weight
 - The structure will be weighed and the weight entered into the formula as "Weight of Structure (grams)."

- An increasing load will be applied to the bridge via the bridge tester until the bridge fails. The reading on the tester gauge will be entered in the formula as "Load."
- The bridge with the highest efficiency number is the winning bridge.
- All efficiency ratings shall be calculated to three (3) decimal places. The highest efficiency rating will be the winner. In the event of a tie, the efficiency rating will be calculated to the next decimal point until a winner is decided.
- An increasing load will be applied to the bridge via the test hook (Diagram C) until the bridge fails. The load will be weighed and the weight entered in the formula as the "Failure Weight."

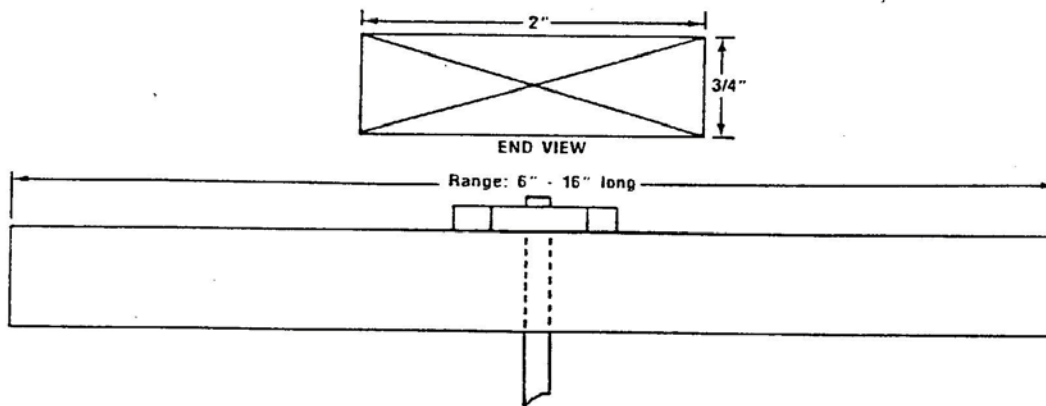

DIAGRAM C

SWEEPSTAKES AWARD

OVERVIEW: The Sweepstakes Award is presented to the chapter earning the highest number of points in competitive events at the annual state conference.

I. CONTEST PURPOSE

The purpose of the Sweepstakes Award is to encourage chapter members to participate in several competitive events and to provide a means to recognize the achievements of that chapter's members at the conference.

II. ELIGIBILITY FOR ENTRY

All IL-TSA chapters in good standing and which are represented at the annual state conference may compete for the Sweepstakes Award.

III. LEVELS OF COMPETITION

There are two levels of competition for the Sweepstakes Award.

IV. TIME LIMITATIONS

The award will be based only on activities at the current state conference.

V. SPECIFIC REGULATIONS

None.

VI. PROCEDURES

Upon the completion of all competitive events, the Competitive Events Coordinator will tally the scores of all chapters entering this event. The chapter earning the highest number of points shall be declared the Sweepstakes Award winner.

VII. REQUIRED CONTEST PERSONNEL AND EQUIPMENT

- Contest coordinator and assistants
- Competitive events score sheets
- Table and chairs for coordinator and assistant

VIII. CRITERIA FOR JUDGING

- Rating on the score sheet will be based upon the following:

First Place -5 points, Second Place -3 points, Third Place -1 point

Should there be a tie in scores, the chapter with the most first-place awards will be the winner. If a tie still exists, the most second-place awards will break the tie, etc.

TECHNICAL DESIGN

OVERVIEW: TSA contestants in Technical Design demonstrate their technical knowledge of drafting by completing a written test and solving an engineering graphics problem using standard board drawing techniques.

I. CONTEST PURPOSE

The purpose of the Technical Design contest is to provide a means for TSA members to demonstrate their knowledge and abilities in drafting.

II. ELIGIBILITY FOR ENTRY

- All IL-TSA members in good standing are eligible to enter the Drafting contest.
- Entries are limited to two (2) per chapter.

III. LEVELS OF COMPETITION

There are two (2) levels of competition in the Technical Design Contest, Level I (grades 6-9) and Level II (grades 10-12), as described in the General Rules.

IV. TIME LIMITATIONS

The length of time allowed for the completion shall be 1 ½ hours.

V. SPECIFIC REGULATIONS

- The Technical Design contest is an individual event.
- A written test may be given. If a written test is given, it shall be objective. It will be worth a total of 100 points and shall be comprised of true/false, matching, and/or multiple choice questions.
- All materials for the written test will be provided at the conference.
- All drawings shall be done on 9" x 12" drafting paper. Paper shall be provided at the conference.
- **All entrants shall provide their own drafting equipment.**
- All lettering on the drawing shall be free hand. No lettering guides or devices shall be allowed. Guidelines for lettering may be used.
- All drawings shall be done in pencil. No inking of drawings shall be allowed. Contest participants may bring their own pencils or use pencils provided. Only No. 2 (HB) lead pencils will be available at the conference.

VI. PROCEDURES

- Contest participants must register for this event in accordance with procedures established for each conference.
- Contestants must be at the assigned testing area before the established starting time for the event.
- Once the event has started with the distribution of the written test or the problem, no additional contestants will be allowed to enter the testing area.
- Contestants will not be allowed to leave the testing area and return after the event has begun.
- Contestants may leave the contest area when they have completed the written test and drawing.
- All drawing problem sheets and drawing entries shall be turned in to the contest coordinator.
- All drawing equipment must be removed from the testing area upon the completion of the event.

VII. REQUIRED CONTEST PERSONNEL AND EQUIPMENT

- Contest coordinator
- A team of judges - ideally three but fewer are acceptable
- A copy of the contest guidelines
- Written tests, pencils, and answer sheets
- Drawing paper, copies of problems, and correct solutions
- Judge's rating sheets
- Pens for judges
- Tables and chairs for contestants

VIII. CRITERIA FOR JUDGING

- Drafting Contest entries shall be evaluated using the following criteria.

LEVEL I

Accuracy of solution	25 points
Placement of views	15 points
Accuracy of Drawing	25 points
Lettering	10 points
Line quality	15 points
Neatness and appearance	10 points
Written test score	100 points
TOTAL	200 points

LEVEL II

Accuracy of solution	25 points
Placement of views	10 points
Accuracy of Drawing	20 points
Dimensioning fundamentals	10 points
Lettering	10 points
Line quality	15 points
Neatness and appearance	10 points
Written test score	100 points
TOTAL	200 points

- Awards

First, Second, and Third place awards will be presented in each level of competition.

TECHNOLOGY BOWL - ORAL

OVERVIEW: Chapter teams entering this event will compete with other teams in a verbal question and answer contest.

I. CONTEST PURPOSE

The purpose of the Technology Bowl - Oral contest is to provide TSA members with the opportunity to work together in teams to demonstrate their knowledge of technological content.

II. ELIGIBILITY FOR ENTRY

- All TSA members in good standing are eligible to enter the Technology Bowl - Oral contest.
- Entries are limited to one (1) five-member team per chapter.

III. LEVELS OF COMPETITION

There are two levels of competition in the Technology Bowl - Oral event.

IV. TIME LIMITATIONS

Teams must be available as scheduled for the oral competition or the team will be disqualified.

V. SPECIFIC REGULATIONS

- Questions used will be alternately selected at random from the seven content areas of the Standards for Technological Literacy.
- No transmitting or recording devices shall be permitted in the contest area. No prompting shall be permitted.
- A total of five questions will be asked per round. No questions will be repeated in another round.
- A bonus question, which will consist of multi-part answers will be used at the end of the round for teams to earn additional points. A team designated individual will answer the bonus question.
- In case of a tie, at least one (1) additional question will be asked until a winner is determined.
- After a question is read, the competing teams will have ten (10) seconds to "buzz in." If neither team can answer the question, another question will be read.
- Teams are allowed to discuss potential answers, but the person who "buzzes in" will have five (5) seconds to answer the question.

- If a team member "buzzes in" before the question is completed, that team has five (5) seconds to give the correct answer without hearing the remainder of the question. If an incorrect answer is given, the question will be repeated for the other team.
- 10 points will be awarded for correct answers, while 10 points will be subtracted for incorrect answers.

VI. PROCEDURE

- Contest participants must register and follow the guidelines for this event in accordance with procedures established for each conference.
- The initial order of participation shall be established by a drawing of team numbers prior to the beginning of the contest.
- After instruction briefing, team members will report to the holding room as designated. Teams will remain in the holding room until called for competition or eliminated. Teams may visit with other teams, however, no advisor or visitors may come into the holding room.
- When instructed to do so, two teams will enter the contest area and be seated according to instructions.
- Team members will not be allowed in the contest area as observers until after the team has been eliminated.
- Once a team is eliminated, it is eliminated entirely.
- Questions will be prepared, by round, prior to the beginning of the contest.
- If equipment malfunctions, the question being asked will automatically be disqualified. A new question will not replace the disqualified question.
- If equipment malfunctions three (3) times during the same round, time will be called by the Contest Coordinator to set up the back-up equipment. After the new equipment has been set up and tested, the contest will continue from the point where it stopped.

VII. REQUIRED CONTEST PERSONNEL AND EQUIPMENT

- Contest coordinator
- Timekeeper
- Moderator
- Table with a rostrum for the moderator
- Two tables and six chairs for the contest teams
- List of chapters entered in the contest

- Lights and controls for contestants tables
- Chalkboard
- Test questions - questions should be previously selected for rounds before the contest begins
- Several sets of tie-breaker questions previously selected

VIII. CRITERIA FOR JUDGING

A team's score is derived from the total correct answers to the questions asked. For each correct answer, the team will receive ten (10) points. If a question is answered incorrectly, or if a member of a team presses a button and cannot answer the question, five (5) points are subtracted from the team's total points. The team with the higher number of points will continue to the next round of competition while the losing team is eliminated from the competition.

TECHNOLOGY BOWL - WRITTEN

OVERVIEW: TSA members entering the Technology Bowl-Written contest will complete a written objective examination covering many aspects of Technology Education.

I. CONTEST PURPOSE

The purpose of the Technology Bowl - Written contest is to allow students the opportunity to demonstrate their knowledge of technical content in a wide variety of technology areas.

II. ELIGIBILITY FOR ENTRY

- All TSA members in good standing are eligible to enter the Technology Bowl - Written contest.
- Unlimited contestants per chapter.

III. LEVELS OF COMPETITION

There are two levels of competition in the Technology Bowl - Written contest.

IV. TIME LIMITATIONS

- The written test will be administered to all students entering this contest at the same time.
- One (1) hour will be allowed for this test.

V. SPECIFIC REGULATIONS

- All necessary materials including pencils, tests, answer sheets, etc. will be provided by the Contest Coordinator. Contestants should bring nothing with them to the testing room.
- Contestants who are not present when the test is distributed will be disqualified and restricted from the test area.
- The test will consist of 100 objective questions including true - false and multiple choice.
- The test will cover the Standards for Technological Literacy.
- Contestants must stop work immediately when time is called by the Contest Coordinator.
- Should a contestant complete the test before the time allocated expires, the contestant will hold his test paper and remain seated quietly without distracting anyone else. Failure to do so may result in disqualification of the contestant at the discretion of the Contest Coordinator.
- All test papers must be turned in before leaving the test area.

VI. PROCEDURE

- All contestants in the Technology Bowl-Written event must register at the designated time and follow the guidelines and procedures established for each conference.
- Contestants must be at the assigned testing area before the established starting time for the test.
- All contestants will follow the Specific Regulations and adhere to all directions provided on site by the Contest Coordinator.

VII. REQUIRED CONTEST PERSONNEL AND EQUIPMENT

- Contest coordinator
- Person to time the test (may be the Contest Coordinator)
- Three (3) to five (5) judges for grading or computer grading facilities
- A stopwatch
- Tables and chairs or armchairs in sufficient quantity to accommodate all contestants
- A room large enough to accommodate all contestants
- Rating sheets for the judges
- Pencils for all contestants
- Test booklets and answer sheets
- Contest results reporting form

VIII. CRITERIA FOR JUDGING

The most correct answers on the written test will determine the winners in this event.

TECHNOLOGY PROBLEM SOLVING

OVERVIEW: TSA teams entering the Technology Problem Solving event are required to use a team approach to provide an adequate solution to a given problem within a specified and limited time frame. Design, function, cooperative teamwork, and originality are the primary elements judged.

I. CONTEST PURPOSE

The purpose of the Technology Problem Solving contest is to provide students with an experience in problem solving. Students working in teams of three will use critical thinking skills in order to develop a satisfactory solution to the stated problem.

II. ELIGIBILITY FOR ENTRY

- All IL-TSA chapters in good standing are eligible to enter the Technology Problem Solving contest.
- All members of each team must be in the same level of competition as stated in the General Rules.
- Entries are limited to two teams of two individuals, per level, per chapter.

III. LEVELS OF COMPETITION

There are two (2) levels of competition in the Technology Problem Solving contest, Level I (grades 6-9) and Level II (grades 10-12), as described in the General Rules.

IV. TIME LIMITATIONS

The allotted time for design and construction of the solution will be one hour-thirty minutes, unless otherwise noted. All contestants in this event must arrive and be in place at the specified time and location.

V. SPECIFIC REGULATIONS

- Teams shall consist of two members. All team members must be in the same level of competition.
- All work must be done in the specified area.
- All materials will be provided. No additional materials will be allowed during construction of the solution.
- All necessary tools will be provided.
- Contestants will be given the problem and judging criteria when entering the contest room. The contest problem and criteria for judging will be available to local TSA advisors after the contest is complete.

- Contest problems will be selected from areas such as, but not limited to:
 - Communication
 - Energy
 - Transportation
 - Production
 - Construction
 - Societal/future
 - Applications of Technology

VI. PROCEDURES

- Contest Participants must register and follow the guidelines for the event in accordance with the procedures established for each conference.
- One team member will check in his/her team with the Contest Coordinator at the time designated for the event to obtain specific information for the event.
- Problem solving teams should assemble in the general area of the contest prior to the designated time for the contest.

VII. REQUIRED CONTEST PERSONNEL AND EQUIPMENT

- Contest coordinator
- A team of judges - ideally three but fewer are acceptable, one can serve as timekeeper
- Stopwatch or clock to time event
- A copy of the contest guidelines
- Judge's rating sheets
- Pencils for judges
- Tables and chairs for the contestants and judges
- Technology problem and judging criteria
- Tools and supplies needed for developing solutions
- Contest results reporting form

TSA STUDENT OF THE YEAR

OVERVIEW: Contestants in the TSA Student of the Year contest are required to submit a resume describing their qualifications and activities during the past year. They will be interviewed by a panel of judges at the state conference.

I. CONTEST PURPOSE

The purpose of the TSA Student of the Year Award is to provide a means to designate and honor outstanding TSA members in the state.

II. ELIGIBILITY FOR ENTRY

- All IL-TSA members in good standing are eligible to be nominated for this award.
- Entries are limited to one (1) per chapter.

III. LEVELS OF COMPETITION

There are two (2) levels of competition, Level I (grades 6-9) and Level II (grades 10-12) as described in the General Rules. Level I candidates will not compete with Level II candidates. Awards may be presented in each level.

IV. TIME LIMITATIONS

- Information listed in the resume may include the past year's activities, chapter involvements, leadership roles, and other items pertinent to the award. Activities listed should relate only to the present school year.
- The length of each contestant's interview shall not exceed twenty (20) minutes.

V. SPECIFIC REGULATIONS

- Entries must be submitted by the advisor of the local chapter.
- The resume entry form provided in the IL-TSA Competitive Events Guide should be used. The form may be photocopied or re-typed but should not be changed.
- A letter of recommendation from the school principal must be included with the application.
- No additional materials will be accepted or considered for judging.
- The entry should be an informative typed report on the activities which apply to the nature of this award.
- The advisor and student should each complete their respective sections of the resume entry form.

- The committee to interview entrants shall consist of at least two (2) but not more than three (3) judges. The following list suggests areas from which these judges might be chosen.
 - The Alumni association
 - University personnel assisting or attending the conference
 - The IL-TSA Board of Directors
 - Local chapter advisors
 - National TSA officers or personnel assisting or attending the conference
 - Local industrial personnel assisting or attending the conference
 - State Board of Education personnel assisting or attending the conference

VI. PROCEDURE

- All resume entry forms should be completed prior to the state conference.
- All materials must be turned in to the Competitive Events Coordinator at the time of registration.
- Three (3) typed copies of the resume form must be submitted for the judge's use.
- Each entrant will be scheduled for a personal interview with a panel of judges.
- This interview is closed. There is to be no audience.

VII. REQUIRED CONTEST PERSONNEL AND EQUIPMENT

- Contest coordinator
- A team of judges - ideally three but fewer are acceptable
- A comfortable and private room with four chairs
- Judge's rating sheets
- Pencils for judges
- List of entries
- Results reporting form

VIII. CRITERIA FOR JUDGING

Individual Evaluation -

Each entrant shall be evaluated on the following:

Personal Appearance 10 points

Grooming (5 pt.)

Appropriate attire (5 pt.)

Interview15 points

Conduct and cooperation (5 pt.)

Voice (5 pt.)

Poise and self-confidence (5 pt.)

Potential Leadership Ability 60 points

Demonstration of initiative and drive (15 pt.)

Participation in and knowledge of TSA (15 pt.)

Leadership roles in TSA and other organizations (15 pt.)

Participation in community affairs (15 pt.)

Career Planning 15 points

Scholastic achievement (5 pt.)

Career plans (5 pt.)

Career understanding (5 pt.)

Resume 10 points

Organization and neatness (5 pt.)

Presentation of facts in an orderly manner (5 pt.)

Total Possible 110 points

Qualification Individuals must meet minimum percentage totals on the individual evaluation to qualify for consideration of this award. The minimum percent of possible points to qualify for consideration shall be 87%. Level I candidates shall not be evaluated on item D - Career Planning.

Level I candidates must score at least 83 points to qualify.

Level II candidates must score at least 96 points to qualify.

Judges will total points, complete all forms, and return the event package to the conference office. All judge's ratings and results are to remain confidential.

One award will be presented for TSA Student of the Year in each level.

S-A-M-P-L-E

COVER PAGE FOR TSA STUDENT OF THE YEAR STUDENT APPLICATION

Use of additional materials will not be accepted

Student's Name

Chapter Name

School Name

Student's Address

Chapter President

Chapter Advisor

CERTIFICATION: "I certify the attached letter of application is a true statement of activities related to (student's name). I further certify that this student is in good standing within the school district and deserving of consideration for this award."

School Principal

Date

TSA STUDENT OF THE YEAR
RESUME APPLICATION FORM

The following items are required for entry in this event:

The resume application form must be typewritten.

A letter of reference from the school principal must accompany this application form.

No additional materials will be accepted for judging.

Student Candidate
Grade in School
Chapter
School
School Address
Chapter Advisor

DIRECTIONS: Advisors should complete questions 1-3 on the following pages. The student candidate should complete questions 4-7.

1. Discuss the personal qualities, chapter involvements, and leadership roles in TSA at the local level which should be considered during the evaluation of this student.
2. Discuss the student's involvement and leadership roles in TSA at the state level.
3. Discuss the student's involvement and leadership roles in TSA at the national level.
4. Discuss the awards and recognitions you have received through your involvement with TSA and other organizations or activities.
5. Discuss the benefits and personal growth you have received through your involvement with TSA and explain how you will apply them in your future endeavors.
6. Discuss your career objectives and the means by which you plan to achieve them.
7. Discuss any additional items which you feel are pertinent to this event.

CERTIFICATION: I hereby certify that the claims and information recorded in this application are true and accurate to the best of my knowledge.

Chapter President
Chapter Advisor
School Principal